

# 2007

## INTERNATIONAL



# SAFETY RULES

© Copyright 2006 MTRRA® MTRAE®

*2007 Changes are underlined.*

*European language variations  
and Metric conversions  
are in brackets [ ].*

### Nomenclature

*(Abbreviations & acronyms)*

CDL:	Commercial Drivers License
Competitor:	Driver
D.O.M.:	Drawn Over Mandrel
Kill Switch:	Switch that shuts off the engine
Mfg:	Manufacture
MTRRA:	Monster Truck Racing Association
MTRAE:	Monster Truck Racing Association Europe
Participant:	Owner/driver, crewmember
R-T:	Ride truck
Race:	A contest between one or more vehicles
RII:	Remote Ignition Interrupt
SFI:	Safety Foundation, Inc.
SPEC:	Specification

### **EU (European Union) nomenclature**

AFFF:	Aqueous Film Forming Foam
CDS:	Cold Drawn Steel (same as DOM in the US)
Kg:	Kilogram
KPH:	Kilometres per hour
£:	EU pounds
M:	Metres
Mm:	Millimetre

Revision #3 - 11/9/2006

## INTRODUCTION

**The purpose of the Monster Truck Racing Association is to provide consistent safety for competitors and spectators. MTRA makes no expressed or implied warranties of safety from publication of or compliance with these rules and regulations. They are intended as a guideline for the conduct of the sport and are in no way a guarantee against injury or death to participants or spectators.**

**Perfect adherence and application of the rules published by MTRA will not assure that all vehicles will perform all safety applications. The individual fabricator and driver have the ultimate control of how the Monster Truck is constructed and operated.**

**Using MTRA rules does not imply that all safety measures are included. MTRA or its representatives assume no liability whatsoever.**

**Any vehicle component not included in these rules or any deviation from these rules will be subject to director's written approval.**

**It is the responsibility of the participant(s) to familiarize his/herself with all MTRA rules.**

## DRUG STATEMENT

The Monster Truck Racing Association (MTRA) strives to create and maintain a healthy environment for all people involved in monster truck related events.

A healthy environment is one in which the use of alcohol and/or drugs does not interfere with the safety and performance of MTRA members. Drugs include all illegal drugs and any and all prescription and/or over-the-counter medications that can affect a person's ability to operate machinery.

These uses place the lives and well being of monster truck participants, event staff and spectators at risk of accidents, injuries, and even death. It is the duty of all members of the MTRA to take responsibility for preventing the dangerous use of alcohol and/or other drugs from adversely affecting the monster truck community.

# Section A

## Competition Trucks

### MTRA® DRIVER LICENSE

All MTRA drivers must have a valid **MTRA Drivers License**. This license must be checked prior to each event.

A **Class “A” driver license** is required when driving in a Certified Points or Purse Race Series and a **Class “B”** for all other types of performances.

Driver member will submit the normal MTRA dues and a copy of their current CDL or CDL equivalent physical when applying for their yearly **MTRA Driver License** or Drivers License **renewal**.

### **DRIVER REQUIREMENTS**

#### **CLASS “A” DRIVERS LICENSE**

Class “B” Drivers must execute 10 performances, in a MTRA Certified Vehicle, witnessed by at least one MTRA Class “A” driver at each performance. The final application must have at least 3 different Class “A” Driver signatures, (you cannot have one driver sign all 10 performances). The MTRA Board of Directors will then evaluate the application and decide whether to issue the license or to require more tests. As a Class “A” driver it will be your duty to watch Class “B” drivers and evaluate their driving. It would be a good idea to give constructive criticism.

#### **CLASS “B” DRIVERS LICENSE**

New drivers will have to perform a prescribed driving test, in an MTRA Certified Vehicle, with 3 MTRA Class “A” Drivers present. The driving test will consist of an in cab familiarity test, vehicle parking, stopping and turning demonstration, and then driving over cars several times at different speeds. The Class “A” Drivers must endorse this performance. The application must then be sent to the MTRA Board of Directors for their approval or disapproval.

### DRIVER & CREW

1. A current CDL or **CDL equivalent [Europe HGV medical required] physical** is required and a copy must accompany each year’s application for an MTRA Driver License renewal. Current physical means a physical at least every (2) two years.
2. All MTRA drivers will be subjected to a **random Drug testing**. If their name is picked, they will be informed and will be given 48 hours to comply with the drug test at one of the 2500 test stations across the country. An independent agency will randomly pick driver names. Non-compliance will be considered an admission of guilt and their MTRA Drivers License and Membership will be canceled. Drivers can be called for drug testing more than once a year.
3. Approved **helmets are mandatory**. All competitors must use an (new spec.) SFI 31.1 full or open face helmet, or (old spec.) **SFI 31.2A (Snell SA)** rated full-face helmet or **SFI 31.1A (Snell SA)** rated open-face helmet. (SA = Special Application Nomex lining Competition Helmet), **SA2000 SNELL** rated helmet are also legal. **SFI 41.2, SFI 41.1** or **SNELL M**, motorcycle helmets are **not** allowed. MTRA recommends helmet restraints. (Straps from underarms to sides of helmet.) Full-face helmets are highly recommended. Helmets must be sent back to the manufacturer for re-inspecting after being dropped or hitting any hard object.  
*(In 2005 the new SFI helmet specs are combining open and closed face helmets to 31.1 for Flame Resistant Motorsports Helmets and 41.1 for Motorsports Helmets (non-flame resistant). The new spec will also have a year of the current specs and it will change every 5 years. New helmet must be a SFI 31.1; the 41.1 will not be legal for a Monster Truck Driver.)*
4. **Eye protection** is required during performances. Goggles and helmet shields that are approved for motor sports competition are recommended Windshields are always required.
5. Approved Motor sport neck collar is required unless the driver is wearing a Hans or similar Device.
6. A Multi-layer **fire retardant safety suits** with a SFI rating of 3-2A/15 and shoes and gloves with a SFI rating of 3.3/5 are required at all times. No tennis shoes allowed. MTRA recommends the use of a head sock when running on Methanol (Alcohol).
7. Drivers must **operate vehicles in a safe manner** at all times. The show or race director has the right to stop and disqualify any driver not operating his or her vehicle in a safe manner.
  - 7b) Vehicles should not **drive over 5MPH** except during performances.
  - 7c) Anytime the **engine is running** a participant should be in the drivers’ seat with complete control of the vehicle.
8. All contestants and the pit crew must be clean, neat and **professionally attired** when appearing before the public.
9. Drivers must be **at least 18 years old**, or be approved by the MTRA Board and have parental or guardian written permission.

10. No one is allowed in the **performance area** during an event, except track officials and a minimum number of crewmembers.
11. Before an MTRA member can perform, the **exhibition area must be cleared** of all spectators and participants.
12. Drivers must, at minimum, **have a seatbelt on** at all times the **vehicle is moving** with 66” tires.
13. The **driver has the final decision** on whether he or she can perform the race or exhibition in a safe manner. MTRA will back the driver 100% if he or she cannot fulfill his or her contractual agreement because of a safety reason.
14. Consumption of **intoxicating agents or drugs** before or during an event by a driver or his or her pit crew will be grounds for disqualification of driver. If the driver is found violating this rule he or she is subject to suspension from MTRA.

## **REMOTE IGNITION INTERRUPT (RII)**

### **MTRA initiated and then required the use of RII’s on all Monster Trucks to enhance the safety of Spectators and Participants.**

15. **RII receivers and transmitters** are required on all Monster Trucks. (“RII” denotes Remote Ignition Interrupt)
16. RII’s must be setup so the **engine will not operate** unless the RII is on.
17. **MTRA members cannot participate** in an event unless all vehicles involved, within the Monster Truck portion of the performance or race, are equipped with RII’s in working order.
18. **RII’s must be tested** before the event and each round of a race, or performance.
19. **Anytime a vehicle moves** above idle speed, a qualified operator must control the RII transmitter. This includes testing; show introductions, race return-lane time, parade laps, etc.
20. **RII’s must always** be switched to the **Right channel**. Only when performing or racing in the Left lane can the switch be set to the Left channel. After racing or performing in the left lane the RII must be switched back to the RIGHT channel. If you have a Center RII channel, it can only be used when a promoters RII transmitter is not present and your RII transmitter is used.
21. MTRA recommends **one person for each RII**; this means one qualified RII operator controlling each vehicle.
22. Anyone **altering or bypassing** the RII receiver will be suspended. Resetting of RII after being stopped, before the RII operator or official gives you permission to start, is the same as bypassing and is subject to suspension.
23. The **RII Light** must be on or above the dash and visible to the track official in front of the vehicle. It must be an Auto Meter Pro Light or an equivalent light, approved by MTRA Board, with a red lens. When applicable a second light will be a lane indicator, right is red and left is yellow. The new Audiax RII comes with both Pro Lights. The lights must be, (two feet apart minimum), mounted at least one foot to each side of the center of the windshield.
24. Your **RII number** must be visible on the right side of the windshield or fender for easy visibility of the race official. It must be a 2” by 2” number. Receiver **antennas** must be vertically mounted.

**Note for RII operators:** Sometimes it is prudent for the RII operator **not** to stop (kill) a vehicle when it is in an awkward situation and let the driver try to power out of that bad situation. **This can only be done when spectators and participants are not in danger.**

**Note: Promoter transmitters** are available for rent from MTRA. RII wiring diagrams are available upon request.

### **MTRA® RII Legal Radios**

**RII Radios LLC. (609) 625-3481**

**Audiax Radios (216) 392-6800**

**Motorsport Communications (866) 966-8672**

[Europe only accepts]

**L. A. Supertrux Ltd. +44 1327 705456**

**Email: RII@supertrux.com**

## VEHICLES

25. **Vehicle Certification** is required before February 15th [Europe 31<sup>st</sup> March] of each calendar year. Vehicle Certification will begin approximately 3 months prior to each calendar year. Membership dues must be paid before Vehicle Certification decals and Drivers Licenses will be issued. Inspectors cannot certify their own vehicles. Vehicles must be re-inspected after sale.
- 25B: Vehicles must be **re-inspected** by a MTRA Inspector after a major crash or rollover.
26. The **current Certification Inspection** sheet must be displayed in the vehicle at all times. The sheet will be visible for all MTRA members and the tech officials. A plastic sheath is recommended for protection against weather.
27. A **kill switch** must be mounted in the center rear of the vehicle. Maximum 6' [2m] high at rear most part of vehicle, (near bumper). Switch must pull to turn off, with a 2" [50mm] diameter, (.125) 1/8" [3.2mm] minimum wire ring, painted florescent red or orange. Switch must kill engine, the same as the in-cab kill switch rule #38.
28. All vehicles must be equipped with a commercially made **back-up alarm**, mounted at the rear most part of the frame. This alarm must be activated anytime vehicle is in reverse. The shift gear lever must mechanically activate the alarm. The alarm sound must face rearward.
29. **Dry or gel type batteries** are **mandatory**. Batteries must be secured and covered with a non-conductive material. Material to be rubber, plastic or Lexan only.
30. All vehicles must be **painted and lettered** with name of vehicle.
31. An external **crossover relief valve**, the type that bolts directly and externally to the orbiter, is required on all vehicles with orbital steering.
32. **Tires** must be 66x43x25 or 66x44x25 (size as marked on tire), unless agreed to by all participants.
33. Monster Truck **minimum weight** is 9000 pounds [4883kg]. Weight includes driver, fuel, water, & oil.
34. All charged **gas shock remote cylinders (accumulators)** must be mounted securely in a position to avoid contact with tires. Caps to be threaded on tubes a minimum of 1/2" SAE fine thread. Remote accumulators to be fastened with metal clamps, no tape or wire ties.
35. All **onboard fuel** must be in an anti-spill tank/fuel cells, properly secured with a minimum of two (2) metal straps, (.125) 1/8" [3.2mm] by 1" [25mm] steel or aluminum, or the manufacturers suggested mounting points. Vent line anti-spill valves are required. Primer fuel tanks have the same requirements as regular fuel tanks. Vented caps are not permitted. Grounding all fuel tank cap rings when fueling, to eliminate static charge, is recommended. MTRA recommends protection on the bottom of plastic fuel tanks.
36. All **tanks/fuel cells and valves** must be located in an open area inside the mainframe rails of the chassis. All fuel lines must be approved steel-braided or high-pressure reinforced rubber.
37. A **tow bar mount** is required on the front and rear of all vehicles. A 2x2" [50 x 50mm] square receiver (trailer hitch type), is recommended.
- 37b) All vehicles should be equipped with a quick release **steering wheel**.

### IMPORTANT NOTES

Don't refuel while battery is charging.

No smoking while refueling. A fire extinguisher must be within easy reach.

### DRIVER'S COMPARTMENT

38. All vehicles must have an **in-cab kill switch**, within easy reach of the driver that shuts off power to all electric fuel pumps, other powered accessories and ignition system (all battery power) with the exception of electrically operated brake systems. Driver must be able to activate it with his or her eyes closed in his or her seat-belted driving position. It must be a push/pull type with push to turn off.
39. All vehicles must have an approved **onboard fire retardant system [Europe AFFF is mandatory]** with a minimum of six (6) properly placed nozzles. A minimum five (5) lb. [2.25kg] tank **can only have** two (2), three (3) nozzle outlet blocks; a 10 lb. [4.5kg] or larger tank can have two (2) or more, three (3) nozzle outlet blocks. The system must be tested each year. (The lines must be blown out with a liquid similar to WD40 and the activating cable tested and lubricated.) The bottle pressure gage and weight must meet Manufacture Specs. (A proper onboard fire system will inhibit the fire while the driver clears the vehicle.) If the content is Halon, keep the outlet spray away from your face; it could stop your oxygen supply. Driver must be able to operate this valve with his or her eyes closed in his or her seat-belted position. An onboard fire retardant system is not required on stock production cabs with sealed Firewalls.
40. Vehicles must have a minimum size 2-1/2 lb. [1.125kg] Halon or ABC type [Europe AFFF] **fire extinguisher** with a working gauge and an attached current inspection certificate, (retail extinguishers have date stamped on unit) (2 year limit). The extinguisher must also be securely mounted with a suitable quick release bracket within the driver's reach.

#### 41. **Firewall & Windshield.**

- a) The **driver's compartment** must be protected against engine compartment flash fires. Firewall material must be a minimum (.063) 1/16" [1.5mm] Steel or Aluminum, (.125) 1/8" [3.2mm] Polycarbonate/Lexan, or Fiberglass. Plexiglas cannot be used. Floor protection is always required.
    - i) **Front engine firewall:** A firewall is required in front of the driver. Firewalls must go from the floor to the roof and from the body skin on one side to the body skin on the other side. A rear Lexan window is not required.
    - ii) **Rear engine firewall:** A firewall is required behind the driver. The firewall must go from the floor to the ceiling. A rear Lexan window is required.
    - iii) **Mid engine firewall:** (Under the cab engines). A firewall is required underneath, behind, and in front of the driver. A rear Lexan window is also required.
  - b) **Windshields** are required on all vehicles at all times. Windshields can be a minimum of (.125) 1/8" [3.2mm] Polycarbonate/Lexan. It is recommended that smoked Polycarbonate/Lexan windshields be used to reduce glare. Glass windshields are permitted on steel bodied vehicles but drivers must wear eye protection.
42. Drivers must be protected from **tire debris**. There will be no exposed areas that would allow the front tires to throw objects at driver or allow objects to bounce and hit driver. Material must be a minimum (.125) 1/8" [3.2mm] Steel or Aluminum (.250) 1/4" [6.4mm] Polycarbonate/Lexan or the Fiberglass body parts. The entire floor of the cab is also considered a tire debris area and must be protected.
43. All vehicles must have an approved 3" [75mm], **5-point harness** that meets SFI 16.1, mounted to the frame or frame outrigger. Driver must wear the harness at all times (this also includes the crotch strap). It is highly recommended that shoulder harnesses be mounted at shoulder height to a maximum of 3" [75mm] above shoulders. All straps must have a manufacturer date stamp on them and they cannot be over 2 years old. Sternum straps and helmet restraints are highly recommended. (Refer to figure #1)
- 43b Ratchet strap seat belt that meet the SFI 16.1 are legal even thou they have a 2" lower strap.
- 43c Hans, or similar device, is recommended for all drivers (there is a quick release for the units)  
When using the Hans or similar device, the regular strap type head restraint must be eliminated, the neck collar can also be eliminated.
44. All **seats** must be properly mounted to the frame or a frame outrigger. MTRA recommends the drivers' seat is in the middle on all new vehicles.
45. Driver compartment **windows** must be removed or down during a performance. There must be 2 exit points from the driver's compartment. Doors must be unlocked.
46. No fuel tanks, fuel lines, batteries, radiators or water hoses are allowed in the **driver's compartment**. Hydraulic steering lines that are located in the driver's compartment must be steel braided lines and must be shielded to deflect the oil, from a line rupture, away from the driver. Shielding material must be strong enough to deflect the oil at the full pressure. A mechanical oil pressure gauge must use braided lines.
47. No Nitrous Oxide, Nitro Methane or any Oxygen Carriers or **Combustion Accelerators** allowed.
48. No **loose objects** allowed in vehicles.
49. There will be **no riders** allowed in a vehicle during a performance.
50. All fuel-injected engines must have a **fuel shutoff** valve, within easy reach of driver. It must be marked with the direction to shut off. (Push or pull)
51. Vehicles must have operable forward and reverse gears and must be equipped with **reverse gear lockout**.
52. All vehicles must be equipped with a **starter interrupter** switch that will allow starter engagement only in the neutral position on a standard or Lenco transmission or park and neutral positions on an automatic transmission. Engines cannot start in reverse or forward gears.

## **ROLLCAGE**

53. All newly constructed or reconstructed vehicles (after an accident, a major remodel job, or being setup for racing), whether steel or fiberglass must have a minimum 2" [51mm] diameter .120 [3.1mm] wall D.O.M. [CDS], **(8) eight point one-piece rollcage**. The frame below the cage must also be a minimum 2" [51mm] diameter .120 [3.1mm] wall D.O.M. tubing or equivalent. The driver must be protected in all directions. No pieced, slip together or sectioned rollcages allowed unless it is a flanged connection with minimum 4 bolts at both connecting points, for removal of engine or other components. It is recommended that all stress points be gusseted. (*Refer to figure's #2 to 5*) **Rollcage and frame tubing repairs** to be sleeved with a 6" [152mm] internal sleeve. (*Refer to figure #3*)
54. All vehicles are required to have an **"X" brace**, [Europe recommends an "A" brace behind drivers head for center seat trucks] extending from the frame to the upper rollcage behind the driver. (*Refer to figure #2*)
55. All **grand fathered steel-bodied** vehicles are permitted to run a 6-point cage. They are not allowed to race in a series or point's race. (*Refer to figures #4 & 5*)

56. SFI 45.1 **fire retardant padding** is required, (minimum thickness (.750) ¾" [19mm]), on the roll cage tubing which is within 18" [457mm] of driver's helmet area above his shoulders.
57. All vehicles lacking stock production doors (fiberglass doors) must have at least one **side bar** no more than 2" [50mm] below the window and one side bar at floor height to protect the driver from side impact. These bars must be parallel to the ground and at least 2" [50mm] in diameter. **(Refer to figure #4)**

## ENGINE

58. All **exhausts** must discharge within a 10-degree angle of being straight up or rearward at a 45 degree down angle. Exhaust can not discharge straight down. No rain caps. All exhaust pipes and mufflers must be securely attached.
59. All carburetors and fuel injection **butterfly shafts** must have dual return to idle springs. A return to idle spring must be located on both butterfly shafts or at both ends of a single shaft. They cannot be attached at the same location. The spring on the throttle pedal does not count as one spring but is recommended.
60. All **throttle linkage** from cab to the engine must be cable operated and must be a positive action push pull type. Cable must not be stretched tight; it must have flex to allow for the engine-to-cab movement.
61. Throttle **toe straps** are required. A "Hot Foot" open loop (**refer to Fig. #6**) or a complete loop will suffice.
62. All **supercharged vehicles** are required to use aluminum blower studs and approved blower restraints. Blower belt guards required, if needed to protect fuel lines. Maximum 871 blowers, 10% overdrive, standard size 2-rotor 3-lobe type only. Rotor angle not to exceed that of standard GM 71 series. No high helix, screw type rotors or internal modifications to increase blower size. Blower rotor maximum length 16" [406.4mm] and a 1 to 1 internal gear ratio with proper rotation.

**Note: ALL THE MTRA LEGAL BLOWER OVERDRIVE COMBINATIONS ARE LISTED IN THE BACK PAGE OF THIS BOOK.**

63. If you want to run anything other than a **single blower**, a naturally aspirated engine, or anything not defined in this book, the Board of Directors must approve it before it can be used or demonstrated.
64. All engines must have a **deflection shield** on both sides of the engine block. Shields must cover the engine block from the center of crank to the top of the block. The heads do not have to be covered. Shield must be securely fastened with a minimum 2 - 3/8" [9.5mm] bolts and made of aluminum or steel minimum (.250) 1/4" [6.4mm] thick. Frame rails can serve as part of the shielding. "Tube chassis trucks cannot use the tubes as part of the engine shield".
65. No engine driven fans, **electric fans** only.
66. No cast iron or **cast steel pulleys** allowed on any moving part that runs at or above the speed of the engine.
67. All vehicles, with **harmonic Balancer**, must have an approved steel harmonic Balancer or must have a (.250) 1/4" [6.4mm] steel or aluminum shield 1" [25mm] wide 360 degrees around the stock Balancer, no more than 1" [25mm] away from Balancer with minimum of 2 fingers attached 180 degrees apart so that Balancer cannot move forward. The water pump may be used as part of shield. (Balancer must be bolted to the crankshaft)
68. **Aluminum engine** blocks will be permitted.
69. Maximum **engine size** is 575 cubic inches [9.422litres].

## TRANSMISSIONS

70. Automatic transmissions must have a **safety blanket** with proper bellhousing straps and it must be 18" [457mm] wide (as measured from the bellhousing to the tail shaft), and it must meet SFI 4-1 requirements. No metal shields are allowed. It must cover from rear of pan forward. (Label sewn on blanket.) Blankets must be in good condition. If blanket has been in a fire, has burnt straps or has been torn, it must be replaced. Metal shields are not allowed. Carbon Fiber shields are allowed. Aftermarket transmission housings that are SFI approved, (without a blanket), will be allowed. (Example: Dedenbear Superglide Transmission Cases with SFI 4.1 and 30.1 certification are legal without external shields), Must be signed off by Driver/Owner.
71. An SFI 29.1 certified **flex plate** is required on all automatic transmissions. There is a 3 year limit on flex plates and then they need to be sent back for re-certification  
(Dedenbear Superglide Transmission cases with SFI 4.1 and 30.1 certifications are legal without external shields.)

## MECH. CLUTCH VEHICLES

72. **Lenco transmissions** are required to have an explosion proof blanket. Couplers must be shielded 360 degrees as per Jackshaft **rule #83**.
73. **Mechanical clutch** vehicles must have an SFI Spec. 6.3 approved explosion proof bellhousing with a current SFI label affixed to it. Any change to the original unit requires re-certification. Any Bellhousing lacking certification must be sent back to the manufacturer for certification or disposed of. Bellhousing certification is good for (2) two years.
74. The **inspection/maintenance hole**, in the bellhousing, is acceptable if made precisely to the specifications outlined in the drawings. A clutch inspection & maintenance hole may be cut on the back face of the housing. The hole may not be longer than an area covering 90 degrees (no longer than 8 ½" [216mm]) of the housing rear surface area. No part of the rotating clutch assembly may extend under the clutch inspection & maintenance hole. **(Refer to fig. #7)**
75. **Clutch maintenance hole** MAY NOT be welded if the original hole in the housing was over 8½" [216mm] in length or 3½" [89mm] wide. All bellhousing holes must be flush on the inside surface when cap is installed. **(Refer to figure #7)**
76. The cover for the **inspection & maintenance hole** must be at least (.250) 1/4 [6mm] thick steel and be fastened with at least twelve (12) 5/16" [8mm] Grade-8 bolts. **(Refer to figure #7)**
77. An approved **steel plate or billet flywheel** is required. No cast iron flywheels.
78. All automotive type engines with bellhousing and clutch will run full **block saver plate** between the engine and bellhousing, either a commercially available unit, or 3/16" [6mm] steel or (.250) 1/4" [6.4mm] aluminum with 5 - 3/8" [9.5mm] Grade 5 or better bolts evenly spaced on the bottom of the bellhousing.

## DRIVELINE

79. **Chain drives** are allowed if they meet all of the specifications in the back of this book. Pages #47 & 48.
80. Maximum distance between **driveshaft loops** will be 12" [305mm] with a minimum of two loops per shaft. Maximum distance between loop and shaft is 2" [51mm]. Loop material shall be steel, no aluminum, not less than (.750) ¾" [19mm] by (.250) 1/4" [6.4mm]. If tubing is used for the loop support brackets, loops must be welded to the tubes, bolts will not be allowed. Two tubes are required for the loop supports; refer to drawing for minimum requirements. **(Refer to figure #8 & 9)**
81. **Loops** must be 360 degrees and round in shape and attached securely to the loop supporting brackets with a minimum of two or more 3/8" [9.5mm] grade-5 bolts or better. **(Refer to figure #8 & 9)**
82. Driveshaft **shields or loops** cannot be attached to anything rotating. **(Refer to figure #8 & 9)**
83. **Jackshafts** (shafts shorter than 12" [305mm]) and couplers (whether on a Lenco or automatic) must have 360-degree enclosures covering both u-joints and the shaft. It can be 2 pieces bolted together. The material size, thickness and mounting must be similar to the regular driveshaft loop specifications, rule #80, 81 & 82. No blankets allowed.
84. When a **coupler** is completely contained (360 degrees) the distance between the coupler and the enclosure can be up to 2" [51mm].
85. Driveshaft **slip yoke** must have a minimum penetration in any axle configuration, equal to half the length of the spline in the most extended position, usually about 2" [51mm]. All drive shaft slip yokes must have a loop similar to the drive shaft loops. It must restrain the slip yoke if it separates from the drive shaft. Clearance not to exceed 2" [51mm] in any direction from the slip yoke. **(Refer to figure #10)**
86. All drive line **U-Joints** will be enclosed in a 360 degree shield, a minimum of 4" [102mm] wide, (.250) 1/4" [6.4mm] thick steel no aluminum. The shield must have (3) three, 1" [25mm] by (.250) 1/4" [6.4mm] mounting straps. The shield should be close enough to joints to restrain any broken parts. Joint should not be visible from side, top or bottom. U-joints and u-bolts to be completely covered. **(Refer to figure #9)**
87. Maximum distance between the **U-joint** and U-joint shield is 2" [51mm]. **(Refer to figure #9)**
88. **Non Planetary** steering axles are required to have a shield covering the axle flange or lockout hub. Minimum (.250) 1/4" [6.4mm] steel.
89. All **pieced wheels** must have the split ring to the inside when mounted on truck or must have four bolts 90 degrees apart and corresponding tabs on the wheels for attaching the ring to the wheel.



## **BRAKES**

90. All vehicles must be equipped with foot operated **hydraulic brakes** in good working order. The brakes must be able to stop the vehicle in its own length at 10 MPH [16KPH]. If your vehicle does not have lockers, wheel brakes are recommended.
91. All **rubber tired** vehicles must be equipped with dual braking systems consisting of two master cylinders with one brake pedal and individual lines running to the front and rear brakes.
92. All **track vehicles** must be equipped with dual braking systems. You must have a foot or hand operated hydraulic brake system as a backup to the normal track lever steering and brake system.
93. Driveline **brake rotors** must be steel billet only. A minimum of three tabs 120 degrees apart, are required to keep the rotor from moving. Tabs are not required if rotor is mounted on the driveshaft side of the pinion. (Steel billet rotors are solid with no webbing or fins in center.) *(Refer to figure #9)*
94. Vehicles equipped with **driveline brakes** are required to have the front brake assembly mounted on the front differential. The rear can be mounted on the transfer case.

## **RULE VIOLATIONS**

95. If an owner, driver or member **breaks a rule**, he or she will be subject to a fine or suspension.
96. If an owner, driver or member **repeatedly breaks a rule** or rules, (3 or more times) he or she will be subject to a fine, suspension and or the loss of his or her MTRA Membership and License.
97. The **inspection sheets** are legal rule violation reports and members will be fined accordingly.
98. MTRA **finest and suspensions** will be issued by the Board of Directors after a hearing with a **75%** Director majority required for ratification. Hearings can be carried out by mail or fax.
99. **Minor rules** affect the safety of the driver only. A minimum fine of \$25.00 [£15.00] for the first time violator and \$50.00 [£30.00] for the repeat offender.
100. **Major rules** affect the safety of spectators and participants. A major rule violation is subject to a maximum fine of \$5000.00 [£2,800.00], up to a year suspension and or termination of MTRA Membership and License. The amount of the fine and/or suspension would depend on the severity of the violation and would be determined by a majority vote of the current MTRA directors.
101. **Non-safety rules** do not affect the safety of the driver, spectator or participant. A fine of \$25.00 [£15.00] for first time violators and \$75.00 [£45.00] for the repeat offender.
102. All **finest must be paid** within 45 days or MTRA Membership and License will be revoked. Written protest will be accepted only after the fines are paid. Membership and License cannot be renewed unless all fines are paid.
103. Promoter Members will be **notified** of all Major rule violations.

# Section B

## Ride Trucks

© Copyright 2004 MTRA®

*The purpose of the Monster Truck Racing Association is to provide consistent safety for competitors and spectators. No expressed or implied warranty of safety shall result from publication of or compliance with these rules and regulations. They are intended as a guideline for the conduct of the sport and are in no way a guarantee against injury or death to participants or spectators.*

*Perfect adherence and application of the rules published by MTRA will not assure that all vehicles will perform safely in all applications. The individual fabricator and driver have the ultimate control of how the Monster Truck is constructed and operated.*

*Using MTRA rules does not imply that all safety measures are included. MTRA or its representatives assume no liability whatsoever.*

*Any vehicle component not included in these rules or any deviation from these rules will be subject to director's written approval.*

### R-T MTRA DRIVER LICENSE

All MTRA drivers must have a valid MTRA **Drivers License**. This license must be on your person when driving a Monster Truck.

A **Class “A” driver license** is required when driving in a Certified Points or Purse Race Series and a **Class “B”** for all other types of performances including Ride Trucks.

Driver member will submit the normal MTRA dues and a copy of their current CDL or CDL equivalent physical when applying for their yearly **MTRA Driver License** or Drivers License **renewal**.

### **DRIVER MINIMUM REQUIREMENTS**

#### **CLASS “B” DRIVERS LICENSE**

New drivers will have to perform a prescribed driving test, in an MTRA Certified Vehicle, with 3 MTRA Class “A” Drivers present. The driving test will consist of an in cab familiarity test, vehicle parking, stopping and turning demonstration, and then driving over cars several times at different speeds. The Class “A” Drivers must endorse this performance. The application must then be sent to the MTRA Board of Directors for their approval or disapproval.

### R-T DRIVER & CREW

1.B A **current CDL or CDL** equivalent physical is required and a copy must accompany each year's application for an MTRA Driver License renewal. Current physical means a physical at least every (2) two years.

2.B All MTRA drivers will be subjected to a **random Drug testing**. If their name is picked, they will be informed and will be given 48 hours to comply with the drug test at one of the 2500 test stations across the country. An independent agency will randomly pick driver names. Non-compliance will be considered an admission of guilt and their MTRA Drivers License and Membership will be canceled. Drivers can be called for drug testing more than once a year.

- 3.B Consumption of **alcoholic beverages or drugs** before or during an event by a driver or his or her pit crew will be grounds for suspension from MTRA.
- 4.B Drivers must be at least **18 years old**, or be approved by the MTRA Board and have parental or guardian written permission.
- 5.B The driver and pit crew must be **clean, neat and professionally attired**.

## **RIDE TRUCK DRIVING RULES**

- 6.B Ride Vehicles must **not** be operated over **25 MPH** [40KPH].
- 7.B Engines must **not** be run over **3000 RPM**. A rev limiter must be installed.
- 8.B The Driver and all Passengers must wear their **seatbelts** at all times the vehicle is moving.
- 9.B Before the Ride Truck can move, the **ride area** must be cleared of all personnel.
- 10.B Vehicle must come to a complete stop before **loading or unloading passengers**.
- 11.B When **engine is running** the driver must remain in his seat unless a manual parking brake is set and the automatic transmission is in park. Otherwise, engine must be shut off each time the driver leaves his seat.
- 12.B No Donuts (spins), no jumping (air), or other **dangerous maneuvers** allowed with passengers onboard.
- 13.B Drivers must **operate vehicles in a safe manner** at all times. The show, race director or promoter has the right to stop any driver not operating his or her vehicle in a safe manner.
- 14.B Wheel **lug nuts** must be re-torqued periodically. (Minimum once a day)
- 15.B Engines must not operate & vehicle must not move unless the **RII receiver is on** and a qualified operator controls the transmitter.
- 16.B The **RII must be tested** at least once a day.
- 17.B **No smoking** in vehicle.

## **R-T VEHICLES**

- 18.B **Vehicle Certification** is required before February 15th of each calendar year. Vehicle Certification will begin 3 months prior to each calendar year. Membership dues must be paid before Vehicle Certification decals and Drivers Licenses will be issued. Inspectors cannot certify their own vehicles.
- 19.B The current **Certification Inspection Sheet** must be displayed in the vehicle at all times. The sheet will be visible for all MTRA members and the tech officials. A plastic sheath is recommended for protection against weather.
- 20.B All vehicles must be equipped with a commercially made **back-up alarm**, mounted at the rear most part of the frame. This alarm must be activated anytime vehicle is in reverse. The shift lever must mechanically activate it. The alarm sound must face rearward.
- 21.B **Batteries** must be secured and covered with a non-conductive material. Material to be rubber, plastic or Lexan only. If under bed, (passenger area), they must be sealed batteries.
- 22.B All vehicles must be **painted** and lettered with name of vehicle.
- 23.B An external **crossover relief valve**, the type that bolts directly and externally to the orbiter, is required on all vehicles with orbital steering.
- 24.B All charged **gas shock remote cylinders** (accumulators) must be mounted securely in a position to avoid contact with tires. Caps to be threaded on tubes a minimum of 1/2" [13mm] SAE fine thread. Remote accumulators to be fastened with metal clamps, no tape or wire ties.
- 25.B All onboard **fuel** must be in an anti-spill tank, properly secured with a minimum of two (2) metal straps, (.125) 1/8" [3.2mm] by 1" [25mm] steel or aluminum, or the manufacturers suggested mounting points. OEM vehicles with stock configured fuel tanks are legal. Grounding all fuel tank cap rings when fueling, to eliminate static charge, is recommended.

26.B All ride trucks must have an adequate passenger loading latter.

## **R-T DRIVER'S COMPARTMENT**

- 27.B All vehicles must have an **in-cab kill switch**, within easy reach of the driver that shuts off power to all electric fuel pumps, other powered accessories and ignition system (all battery power) with the exception of electrically operated brake systems. Driver must be able to activate it with his or her eyes closed in his or her seat-belted driving position. It must be a push/pull type with push to turn off.
- 28.B Vehicles must have a minimum size 2-1/2 lb. [1.25kg] Halon or ABC type **fire extinguisher** within the driver's reach, with a working gauge.
- 29.B All Ride Truck Seats must have approved seatbelts, mounted to the frame or frame outrigger. **(Refer to figure #1 Page 15)**
- 30.B No fuel tanks, fuel lines, batteries, radiators or water hoses are allowed in the **driver's compartment** or in the passenger ride areas. Hydraulic steering lines that are located in the driver's compartment or passenger area must be steel braided lines and must be shielded to deflect the oil, from a line rupture, away from the driver and passengers. Shielding material must be strong enough to deflect the oil at the full pressure. A mechanical oil pressure gauge must use braided lines.
- 31.B **No Blowers** (superchargers), Nitrous Oxide, Nitro Methane or any Oxygen Carriers or **Combustion Accelerators** allowed.
- 32.B Vehicles must have operable forward and reverse gears and must be equipped with **reverse gear lockout**.
- 33.B All vehicles must be equipped with a **starter interrupter** switch that will allow starter engagement only in the neutral position on a standard transmission or park and neutral positions on an automatic transmission. Engines cannot start in reverse or forward gears.

## **R-T ROLLCAGE**

- 34.B All **Fiberglass Cab Ride Trucks** must have a minimum 2" [51mm] diameter .120 [3.0mm] wall D.O.M., (6) six point one piece **rollcage** with a rear (X) brace behind the driver. The **(passenger area)** must have a **rollcage** mounted to the frame or frame outriggers sufficient to protect the passengers. This includes a rollbar, with an "X" brace, on each end of the passenger seating area. **(Refer to figure's #2b to #4b)**
- 35.B **Roll bar Padding** is required on all the rollcage within 18" [457mm] of driver and passengers head areas above his shoulders. It is recommended padding be fireproof material. The new SFI 45.1 fire retardant padding, 3/4" [19mm] minimum is preferred.

## **R-T ENGINE & TRANSMISSIONS**

- 36.B All **exhaust** pipes and mufflers must be securely attached. It is suggested the exhaust discharge forward of the passenger area.
- 37.B All carburetors and fuel injection **butterfly shafts** must have dual return to idle springs. A return to idle spring must be located on both butterfly shafts or at both ends of a single shaft. They cannot be attached at the same location. The spring on the throttle pedal does not count as one spring but is also recommended, unless it is a stock, steel cab, factory configuration.
- 38.B All **throttle linkage** from cab to the engine must be cable operated and must be a positive action push pull type unless it is a stock OEM, steel cab, factory configuration. **Throttle toe straps** are required and they must be open on the brake side unless it is a stock, steel cab, factory configuration. **(Refer to Figure #6 Pg. 20)**
- 39.B **No Mechanical clutch** vehicles unless it is a stock OEM, steel cab, factory configuration.

## **R-T DRIVELINE**

- 40.B All **chain-drives** must be shrouded in all directions with a minimum of (.250) 1/4" [6mm] aluminum or steel. This shroud must restrain all internal moving parts.
- 41.B All **pieced wheels** must have the split ring to the inside when mounted on truck or must have four bolts 90 degrees apart and corresponding tabs on the wheels for attaching the ring to the wheel.

## R-T BRAKES

- 42.B All vehicles must be equipped with foot operated **hydraulic brakes** in good working order. The brakes must be able to stop the vehicle in its own length at 10 MPH [16KPH]. If your vehicle does not have lockers, wheel brakes are recommended.
- 43.B All rubber tired vehicles must be equipped with **dual braking systems** consisting of two master cylinders or a dual cylinder master cylinder with one brake pedal and individual lines running to the front and rear brakes.
- 44.B Driveline **brake rotors** must be steel billet only. A minimum of three tabs, 120 degrees apart, are required to keep the rotor from moving. Tabs are not required if rotor is mounted on the driveshaft side of the pinion. (Steel billet rotors are solid with no webbing or fins in center.) (*Refer To figure # 9 Page 25*)
- 45.B Vehicles equipped with **driveline brakes** are required to have the front brake assembly mounted on the front differential. The rear can be mounted on the transfer case.
- 46.B A manually operated **parking brake** is highly recommended.

## R-T RULE VIOLATIONS

- 47.B If an owner, driver or member **breaks a rule**, he or she will be subject to a fine or suspension.
- 48.B If an owner, driver or member **repeatedly breaks a rule** or rules, (3 or more times) he or she will be subject to a fine, suspension and or the loss of his or her MTRA Membership and License.
- 49.B The **inspection sheets** are legal rule violation reports and members will be fined accordingly.
- 50.B MTRA **finances and suspensions** will be issued by the Board of Directors after a hearing with a **75% Director** majority required for ratification. Hearings can be carried out by mail or fax.
- 51.B **Minor rules** affect the safety of the driver only. A minimum fine of \$25.00 [£15.00] for the first time violator and \$50.00 [£30.00] for the repeat offender.
- 52.B **Major rules** affect the safety of spectators and participants. A major rule violation is subject to a maximum fine of \$5000.00, [£2,800.00] up to a year suspension and or termination of MTRA Membership and License. The amount or the fine and or suspension would depend on the severity of the violation and would be determined by a majority vote of the current MTRA directors.
- 53.B **Non-safety rules** do not affect the safety of the driver, spectator or participant. A fine of \$25.00 [£15.00] for first time violators and \$75.00 [£45.00] for the repeat offender.
- 54.B **All fines** must be paid within 45 days or MTRA Membership and License will be revoked. Written protest will be accepted only after the fines are paid. Membership and License cannot be renewed unless all fines are paid.
- 55.B Promoter Members will be **notified** of all Major rule violations.

# Section C

## **RECOMMENDED MTRA PROTEST PROCEDURE:**

Cubic inch tear down	\$250.00 [£140.00]
Fuel test	\$100.00 [£56.00]
Blower size	\$150.00 [£85.00]
Weight	\$50.00 [£30.00]

**MTRA will treat all protest infractions as a major rule violation and penalties will be issued accordingly.**

### **2006 MTRA®**

#### **DIRECTORS & OFFICERS**

<b>Bob Chandler</b>	<b>Chairman of the Board</b>
<b>Jeff Bursey</b>	<b>President</b>
<b>Bobby Holman</b>	<b>Vice President</b>
<b>Tim Hall</b>	<b>Safety</b>
<b>Andy Hoffman</b>	<b>Director</b>
<b>Scott Bryant</b>	<b>Promotions and Sponsors</b>
<b>George Eisenhart</b>	<b>Membership</b>
<b>Doc Riley</b>	<b>Consultant</b>
<b>Robyn Brow</b>	<b>Secretary/Treasurer</b>
<b>Destiney Conley</b>	<b>Administrator</b>

### **2006 MTRAE®**

#### **EU, OFFICERS AND DIRECTORS**

<b>Nigel Morris</b>	<b>President</b>
<b>Ian Batey</b>	<b>Officer</b>
<b>Tony Dixon</b>	<b>Officer</b>

© Copyright 2006 MTRA® MTRAE®

## Useful Information

### Weights:

Oil 1 gallon = 7.0 Lbs. 1 qt. = 1.75 [3.78 litres]

Gas 1 gallon = 6.2 Lbs. 1 qt. = 1.55 [3.78 litres]

Water 1 gallon = 8.4 Lbs. 1 qt. = 2.10 [3.78 litres]

### Tubing Weights:

2" x .120 wall D.O.M. tubing = 2.409 Lbs. per foot.

[50mm x 3.1mm CDS = 3.49KG per Metre]

1-1/4" .095 wall D.O.M. tubing = 1.172 Lbs. per foot.

[31.75mm x 24.13 CDS = 1.69KG per Metre]

### Metric and Standard Conversion

#### Length:

1 Kilometer = 1000 meters = 3280.83 ft. = .625 miles

1 Meter = 100 centimeters = 39.37 in. = 1.09 yds.

1 Centimeter = .3937 inch

1 Mile = 1.609 kilometers = 5280 ft.

1 Inch = 2.54 centimeters = 25.4 millimeters

1 Yard = .91 meters

#### Mass:

1 Cubic inch = 16.387 cubic centimeters

1 Cubic centimeter = .061024 cubic inches

1 Kilogram = 1,000 grams = 2.2045855 Lbs.

1 LB = 453.6 grams ~ 1 Ounce = 28.35 grams

Kilograms divided by 2.20 = Lbs. ~ Lbs. x 2.20 = kilos

#### Volume:

1 Liter = 100 cubic centimeters or 61.025 cubic inches

#### Formulas:

Circumference =  $\pi$  x diameter =  $\pi D$

Area of circle =  $\pi$  x (radius x radius) =  $\pi r^2$

Volume of cylinder = area x height

$r^2$  = radius squared = radius x radius

$\pi$  = "pi" = 3.141592 = squared

ci = cubic inch cc = cubic centimeter

#### Volumes:

bore<sup>2</sup> x 12.87 deck clearance = cc of deck clearance.

bore<sup>2</sup> x .7854 x deck clearance = ci of deck clearance.

bore<sup>2</sup> x 12.87 x thickness of gasket = cc of head gasket.

bore<sup>2</sup> x .7854 x thickness of gasket = ci of head gasket.

#### Displacement:

bore x bore x stroke x .7854 x # of cyl. = Displacement

## Vehicle/Driver Specifications Reference List

Flywheel SFI \_\_\_\_\_ Mfg. \_\_\_\_\_ Serial # \_\_\_\_\_ Exp. Date \_\_\_\_\_

Bellhousing SFI 6.3 Mfg. \_\_\_\_\_ Serial # \_\_\_\_\_ Exp. Date \_\_\_\_\_ (2yr max)

Flex plate SFI 29.1 Mfg. \_\_\_\_\_ Serial # \_\_\_\_\_ Exp. Date \_\_\_\_\_

Trans Blanket SFI 4.1 Mfg. \_\_\_\_\_ Serial # \_\_\_\_\_ Exp. Date \_\_\_\_\_

Harness SFI 16.1 Mfg. \_\_\_\_\_ (2yr max) Serial # \_\_\_\_\_ Exp. Date \_\_\_\_\_

Firesuit SFI 3-2A/15 Mfg. \_\_\_\_\_

Gloves/Shoes SFI 3.3 Mfg. \_\_\_\_\_

Neck Collar SFI 3.3 Mfg. \_\_\_\_\_

Helmet SFI 31.1 or 31.2 or SA2000 Date \_\_\_\_\_

Fire Extinguisher Type \_\_\_\_\_ Date \_\_\_\_\_

Fire System Lbs. \_\_\_\_\_ Date tested \_\_\_\_\_

CDL Date \_\_\_\_\_ (2yr max)

RII Radio Manf. \_\_\_\_\_

Certification Date \_\_\_\_\_

Vehicle Weight \_\_\_\_\_

Rollcage Size/Thickness \_\_\_\_\_

Rollcage Padding SFI 45.1 Size \_\_\_\_\_

Supercharger Size \_\_\_\_\_  
i. % Overdrive \_\_\_\_\_ Rotor length \_\_\_\_\_

Engine Make \_\_\_\_\_ Cubic Inch \_\_\_\_\_



**Rule Revisions**

**Page #** \_\_\_\_\_

---

---

---

**Page #** \_\_\_\_\_

---

---

---

**Page #** \_\_\_\_\_

---

---

---

---

**Rule change or update suggestions**

---

---

---

---

---

---

---

---

---

---

---

---

Use this section to inspect your vehicle before contacting a MTRA® certified inspector.

## SECTION "A" EXTERNAL CHECK

Helmet Snell SA2000/SFI 31.1 or 2 & Firesuit  
Rll Trans & Rec, Eng will not start with Rll off  
Rll lights 12" from center, Number 2"x 2"  
Rear kill switch, pull type, must kill battery power  
Battery secure & covered, Dry or Gel type only  
External Crossover Relief bolted to orbiter  
9,000 lbs min weight  
Shock accumulators securely mounted  
Fuel tanks anti-spill securely mounted  
Firewall & windshield required  
Seat mounted to frame or frame outriggers  
No combustion accelerators

### Engine

Exhaust must discharge vertical or 45 deg down  
Carb or Inject butterfly shafts dual return springs  
Throttle linkage must be push/pull type cable  
Deflection shield on both sides of engine  
Blower; max 10% overdrive, 871, 16" rotors, etc  
Elect fans only, no cast iron or cast steel pulleys  
Approved harmonic balancer/shield  
575 Cubic inch engine maximum

### Transmission & Clutch

SFI 4.1 Trans blanket not torn or burnt  
Approved SFI flex plate  
Lenco blanket & 360 deg enclosure  
Approved explosion proof bellhousing, not welded, approved hole cover  
Clutch; approved steel plate or billet flywheel  
Clutch; full block-saver plate

### BRAKES & DRIVELINE

Driveline loops, max 12" OC, min 2 loops  
Driveshaft loops, 360 deg & round  
Jack shafts & couplers 360 deg enclosure  
Slip yoke min penetration 2" in all config  
U-Joint enclosed 360 deg, guard dist. 2"  
Chain drives, meet MTRA specifications  
Dual brake system, 2 master cyl, one brake pedal  
Steel billet rotors 3 tabs

## SECTION "B" IN-CAB

Rll receiver antenna mounted vertical  
Current Vehicle Cert Check sheet displayed  
Commercial back-up alarm, mech activated  
In-cab kill switch shuts off battery, push type  
Fire retardant system, 6 nozzles  
2½ lb Halon or ABC fire exting. with gauge 2 yr  
Driver protected from tire debris  
3" 5 pt harness, mount to frame/outriggers 2 yr  
No fuel or fuel lines, batteries, radiators or water hoses in the driver's compartment  
In-cab fuel shutoff  
Forward/reverse gear lockout  
Starter interrupter – park/neutral start only  
Rollcage & frame repairs require 6" internal sleeve 8 point, one piece, 2"OD, .120 wall

**DOM tubing, driver "X" brace from frame to top**  
**Padding; 3/4" SFI 45.1, by drivers head**  
**2 rollcage sidebars**  
**Throttle toe strap**

## SECTION "C" DRIVER IN-CAB

**Can the driver operate the kill switch & fire system with his eyes closed**  
**Test kill switch and RII with engine running**  
**Foot operated Hydraulic brakes**  
**Max stopping distance, vehicle length at 10 mph**

# CHAIN DRIVE TRANSFER CASE SPECIFICATIONS

**CHAIN SIZE:** Triple 60, Minimum. Though there are double chains that are as strong or stronger, a triple chain is recommended.

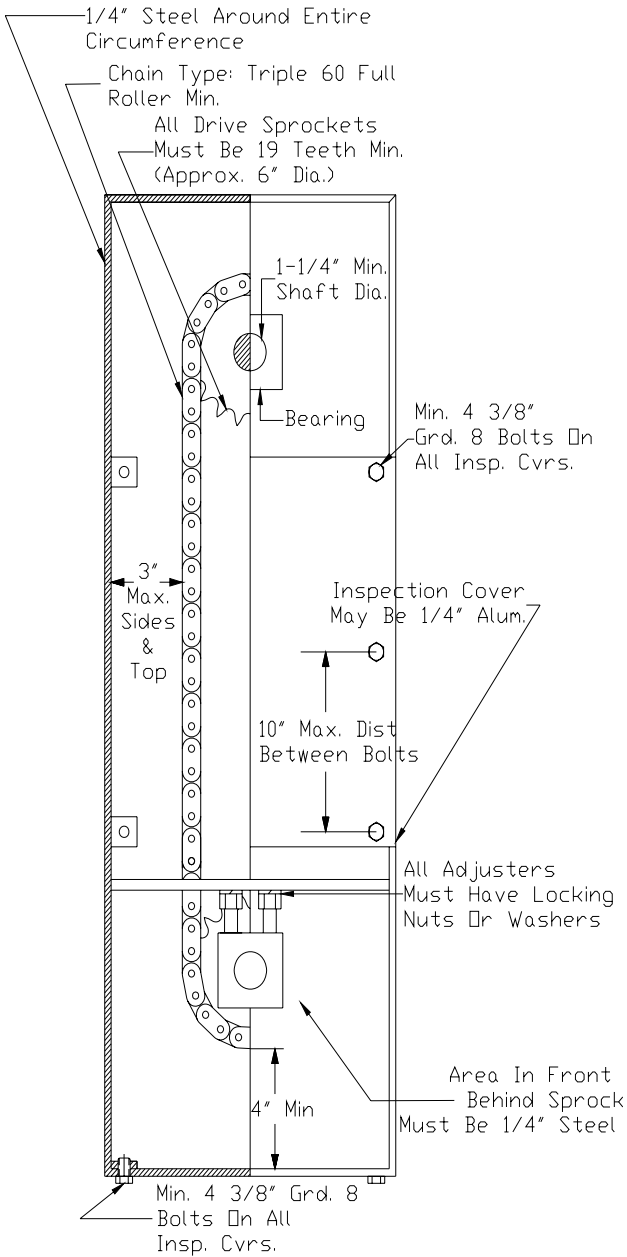

**CHAIN TYPE:** Chain must be full roller type and riveted construction. No spring clip master links allowed. Master link must be riveted or cotter pin type. Only one master link is allowed in the chain. Riveted master link or continuous loop chain is recommended.

**SPROCKETS:** All drive sprockets must be nineteen (19) tooth (Approximately six inches in diameter) minimum.

**CONSTRUCTION:** 1/4" steel minimum must be used for the outer frame case. It must cover all four sides (top to bottom) for 360 degree coverage (The entire circumference). The case must be wide enough to cover the chain completely as viewed from the side. The case must be securely attached to the chassis. The case can be welded to the frame or part of the chassis structure providing the minimum material requirements are met. Chain cannot be more than three (3) inches from outer frame on the sides and top of the case. The case must have enough room for the chain to gather in the bottom in the event of a chain failure. Suggested minimum distance from the bottom of the case to the lowest point of the chain is four (4) inches. Inspection Covers must give Inspectors access to see and measure size of the chain, sprockets, and distance between the chain and case. The case frame and inspection covers must prevent any part of the chain, sprockets, or shafts from escaping. No part of the chain or internals should be seen from outside the case once all inspection covers are secured. Any part of the case where adjusters, tensioners, or shaft bearings are attached must be 1/4" steel, minimum. Inspection covers can be 1/4" steel or aluminum, minimum. Any removable part of the case must be secured with a minimum of 4 (One at each corner) 3/8" Grade 8 bolts. Maximum center to center distance between any bolt along any edge of an inspection cover (I.E. horizontal and vertical edges) is 10". See illustration.

**TENSIONERS AND ADJUSTERS:** The chain drive must incorporate tensioners or adjusters. Both must have locking bolts or nuts to prevent unloosening of the chain.

**CHAIN LIFE:** Maximum allowable chain life is two (2) years. The entire chain and its master link must be replaced after two years of service.

**SHAFT SIZE:** Minimum shaft size is 1-1/4" inches.

Approval of the chain drive transfer case will be granted based on complete following of these specifications. No exceptions allowed.

**M T R A® BLOWER  
OVERDRIVE COMBINATIONS**

47	46	45	44	43	42	41	40	39	38	37	36	35	34	33	32	31	30	29	28	27	26	25	LOWER PULLEY
43	42	41	40	39	38	37	36	35	34	33	32	31	30	30	30	29	28	27	26	25	25	25	UPPER PULLEY
44	43	42	41	40	39	38	37	36	35	34	33	32	31	31	31	30	29	28	27	26			UPPER PULLEY
45	44	43	42	41	40	39	38	37	36	35	34	33	32	32	32								UPPER PULLEY
46	45	44	43																				UPPER PULLEY
70	69	68	67	66	65	64	63	62	61	60	59	58	57	56	55	54	53	52	51	50	49	48	LOWER PULLEY
64	63	62	61	60	59	58	57	56	55	54	53	52	51	51	50	49	48	47	46	45	44	44	UPPER PULLEY
65	64	63	62	61	60	59	58	57	56	55	54	53	52	51	51	50	49	48	47	46	45	45	UPPER PULLEY
66	65	64	63	62	61	60	59	58	57	56	55	54	53	52	52	51	50	49	48	47	46	46	UPPER PULLEY
67	66	65	64	63	62	61	60	59	58	57	56	55	54	53	53	52	51	50	49	48	47	47	UPPER PULLEY
68	67	66	65	64	63	62	61	60	59	58	57	56	55	54	54	53	52	51	50	49	48	47	UPPER PULLEY
69	68	67	66	65																			UPPER PULLEY

**STRENGTH GRADES AND IDENTIFICATION MARKINGS**

STRENGTH GRADE MARKINGS					
DEFINITION	SAE GRADES 1 & 2 ASTM A-307 COMMON COMMERCIAL QUALITY	3 RADIAL LINES *SAE GRADE 5 ASTM A-449	LAWSON TUFF-TORQ®	6 RADIAL LINES *SAE GRADE 8 ASTM A-354BD	LAWSON TRU-TORQ®
MATERIAL	LOW CARBON STEEL	MEDIUM CARBON STEEL QUENCHED & TEMPERED	SELECTED MEDIUM CARBON STEEL, QUENCHED & TEMPERED	MEDIUM CARBON ALLOY STEEL QUENCHED & TEMPERED	SPECIAL ANALYSIS ALLOY STEEL QUENCHED & TEMPERED

Figure #1

SEAT BELT & SHOULDER HARNESS  
SUGGESTED MOUNTING POSITIONS

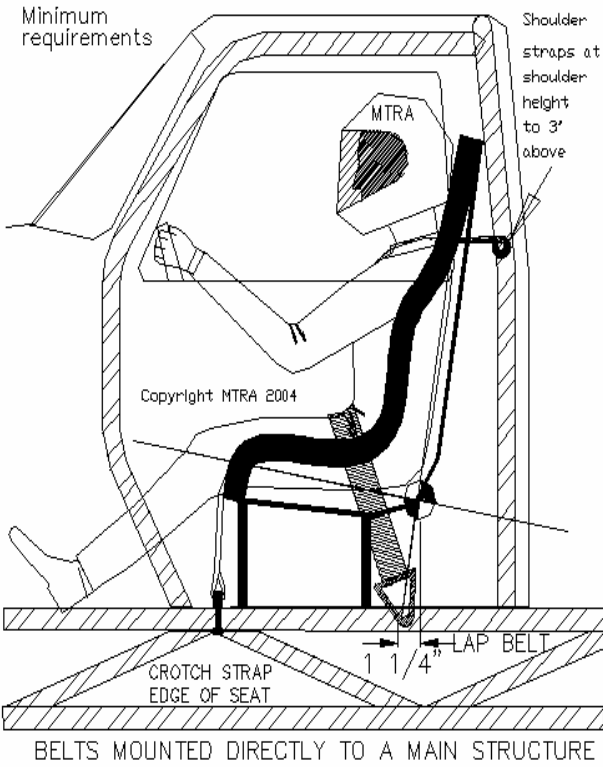

Figure # 2

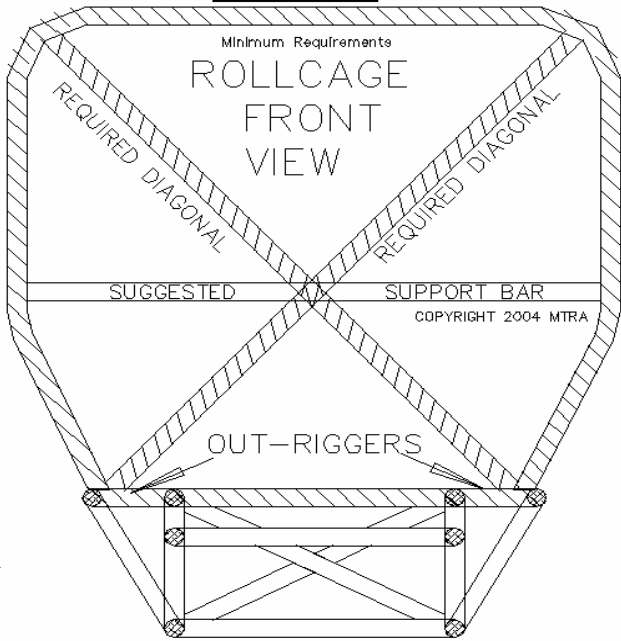

FIG. # 2b

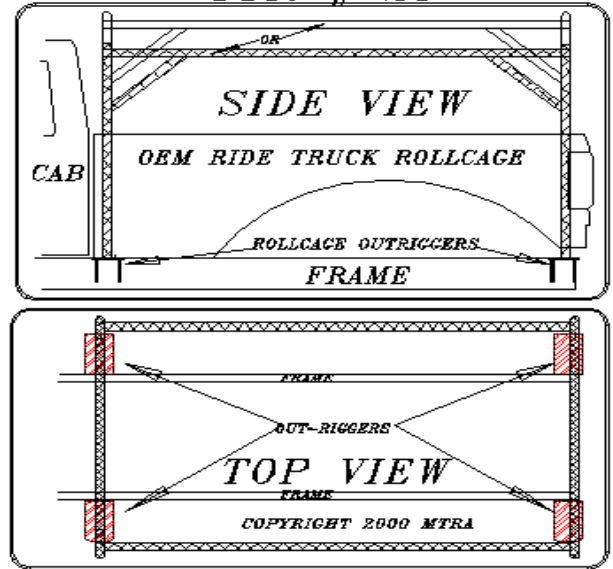

Figure #3

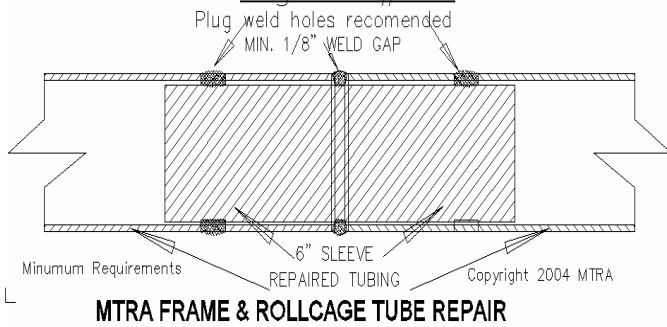

Figure # 3b

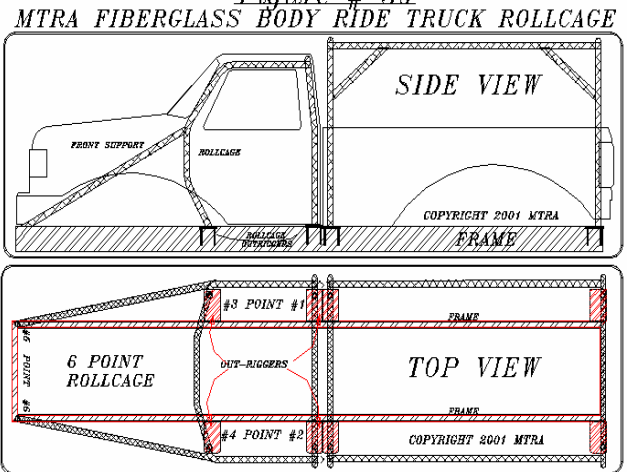

Figure # 4b

RIDE TRUCK ROLL CAGE RECOMMENDED DESIGNS

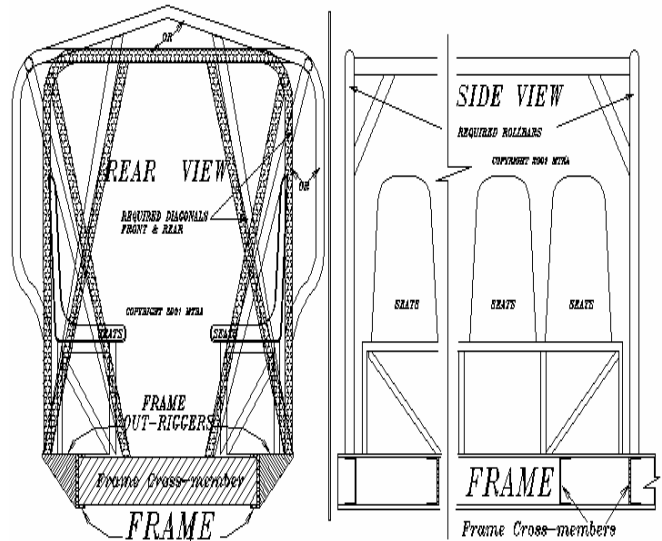

Figure #5

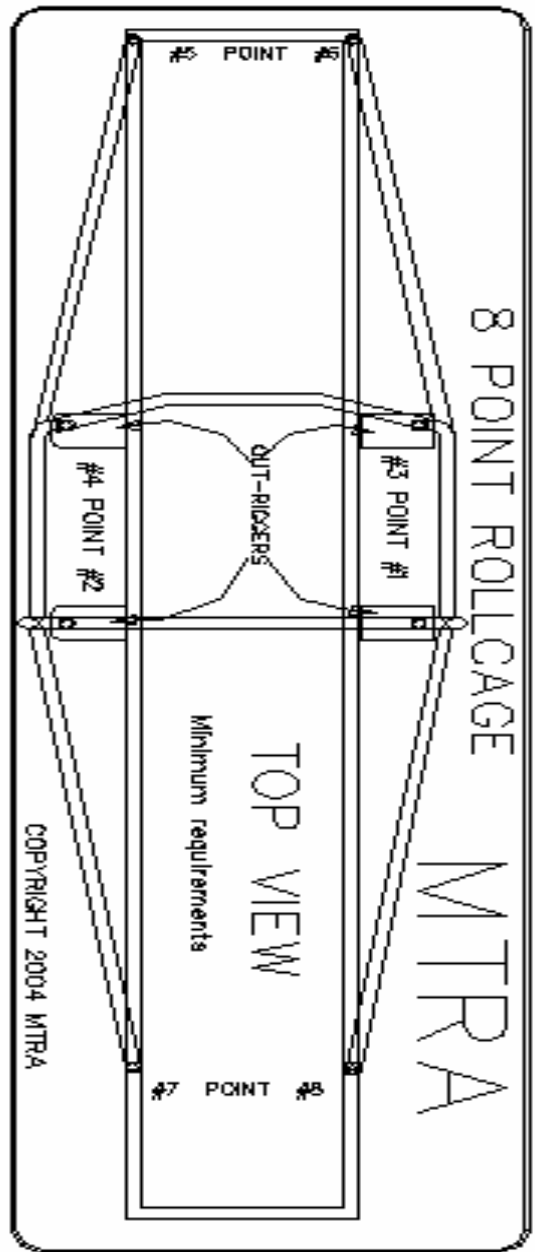

Figure #4

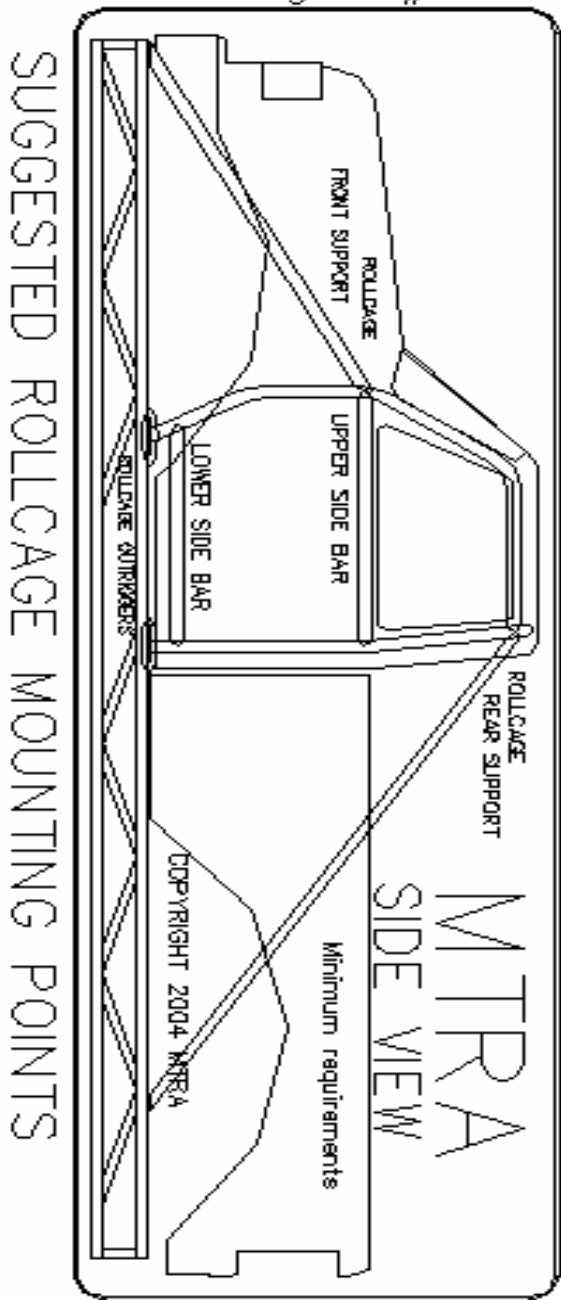

Figure #6

